



DURALIS CONNECT

Durability of a premium water heater with Wi-Fi connectivity



- 1 High-density polyurethane foam 0% CFC
- 2 Diamond-quality enamel
- 3 ACI hybrid anti-corrosive protection
- 4 Electronic sensor
- 5 Enamelled sleeve
- 6 Steatite dry heating element
- 7 Stainless steel water inlet
- 8 Electronic thermostat

CHARACTERISTICS

Wi-Fi Connectivity and Remote piloting

ACI hybrid technology: maximum protection against corrosion

User-friendliness

- Easy to maintain: Heating element removable without draining the tank
- IP 25 - full compliance with European standards for electrical safety and user protection

* Depending on models.

BENEFITS FOR YOUR CLIENTS

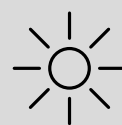

Comfort

- Ergonomic and intuitive control panel
- Heating light indicator



Quality - Durability

- ACI Hybrid system for optimum protection of the tank
- Steatite technology: Ceramic dry heating element adapted to highly mineralized, hard or desalinated water
- Diamond-quality enamel



Savings

- ECO+ Iode: Automatic operation according to consumer's habits thanks to self-learning program
- Absence mode: Allows to create energy savings when away from home
- Remote piloting via the Cozytouch application (available on Google Play and Apple Store)

ELECTRIC WATER HEATER 150 TO 200 VERTICAL WALL-MOUNTED 300 FLOOR-STANDING



For more information see p. 70 and 71



INSTALLATION DIMENSIONS (in mm)

VERTICAL WALL-MOUNTED

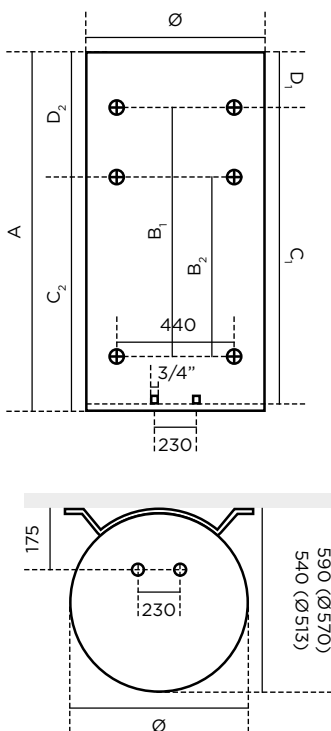

FLOOR-STANDING

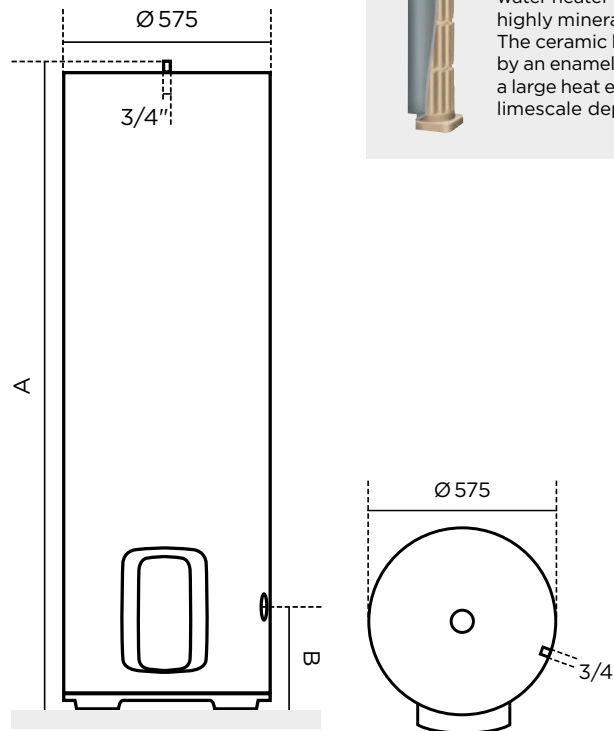

STEATITE TECHNOLOGY

Thanks to unique Steatite technology, the water heater is well adapted to aggressive, highly mineralised and desalinated water. The ceramic heating element is protected by an enamelled steel sleeve, which grants a large heat exchange surface and reduces limescale deposits.

TECHNICAL DATA

DURALIS					
Model	Output (W)	Voltage (V)	Energy consumption at 65°C (kWh/24)	Heating time	Hot water capacity at 40°C
Wall-mounted					
150	2200	230	1,53	4h27	275
200	2200	230	1,92	6h05	373
Floor standing					
300	3000	230	2,36	6h15	535

DIMENSIONS

DURALIS													
Model	Dimensions (mm)										Net weight (kg)	ErP Energy class	Profile
	Ø	A	B	B2	C	C1	C2	D	D1	D2			
Wall-mounted													
150	513	1155	-	500	-	1050	750	-	105	405	35	C	L
200	513	1475	-	700	-	1050	950	-	425	525	45	C	L
Floor standing													
300	575	1765	270	-	160	-	-	30	-	-	23	C	L

