

Features & Benefits

- Thermostat-regulated
- Condensation protected
- Minimumflow available
- Complete range of accessories

Fresh 100 Thermo

Thermostat regulated wall vent designed to provide a continuous airflow into the building/house. Fresh 100 Thermo is supplied with filter and condensation protection. The vent is continuously regulated by the outdoor temperature. Fresh 100 Thermo is also available in a sound reduced model (Fresh 100 Thermo-dB).



Fresh 100 Thermo



Fresh 100 Thermo-dB

Specification

Product	Description	Art. no.
Fresh 100 Thermo Individually packed	Complete vent with wall pipe Ø98/102mm	188005
Fresh 100 Thermo Bulk	Complete vent with wall pipe Ø98/102mm	880005
Fresh 100 Thermo Internal part	Internal part	870013
Fresh 100 Thermo-dB Bulk	Complete sound-reduced vent, wall pipe Ø98/140 x 400 mm	800019

The vent can be adjusted to special requests (larger coverplates, other pipe-lengths etc).

Technical data

Capacity:	7,5 l/s at 10 Pa
Wall opening:	Ø105mm (standard vents) or Ø150 mm (sound-reduced vent)
Material:	ABS-plastic (recyclable)
Colour:	White, RAL 9010

F100 Thermo

Air supply vent

Description/function

Standard vent

Thermostat regulated wall vent designed to provide a continuous airflow into the building/house.

A complete set contain internal part, wall pipes and external grille. The pipes fit telescopically which provides a flexible join.

Internal part

The internal part is supplied with filter and condensation protection. The thermostat is continuously regulated by the outdoor temperature. It automatically closes when the temperature drops and opens again as it increases.

Sound-reduced vent

The sound-reduced model has another wall pipe than the standard. Besides a dB-pipe the vent also contain two coverplates.

The standard length of the dB-pipe is 400mm but can easily be cut to requested length (max.1200mm).

Placement

A high placing is recommended preferably above a radiator. With this solution the incoming air mixes with the convection flow of warm air, ensuring maximum comfort.

Fresh 100 Thermo, Ø102mm

Pos.	Description	Art no
1	Fresh 100 Thermo internal part incl rubber seal (art no 008247)	870013
2	Wall pipe 102x50mm	661050
3	Wall pipe 98/102 x 100mm	188009
4	Adapter 10, 102x60mm	661063
5	External grille #150	801701

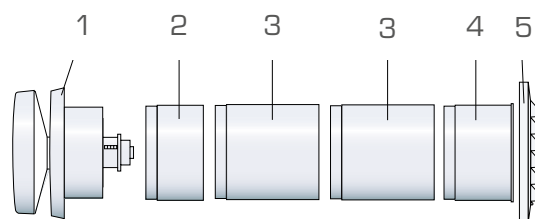

Fresh 100Thermo-dB, Ø140mm

Pos.	Description	Art no
1	Fresh 100 Thermo-dB internal part incl cover plate #165	870014
2	dB-pipe Ø98/140 x 400mm	855004
3	External dB-grille #165	861651

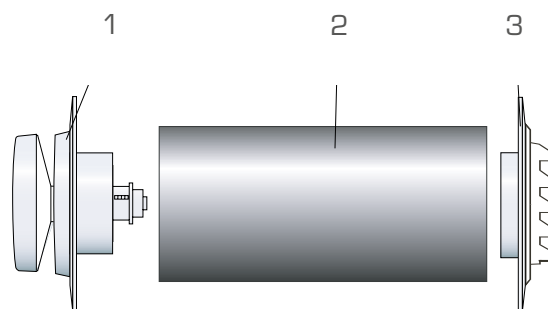

Function/adjustment

The vent is supplied with a built-in thermostat, pre-set at the standard position to start closing at +10°C and to be completely shut at -5°C.

The pre-set temperature settings can be adjusted by turning the front cover clockwise or anti-clockwise. Each mm is equivalent to $\pm 1^\circ\text{C}$. One complete turn is equivalent to 4mm = $\pm 4^\circ\text{C}$. The standard setting can easily be reinstalled by turning the front cover clockwise until a clicking sound is heard. A minimumflow can be set by using Thermo-bricks (accessory). This prevents the vent from closing completely. Each brick is equivalent to a damper opening of 2mm. The bricks are easily installed behind the front cover. Each brick gives approx 2.5 l/s at 10 Pa.

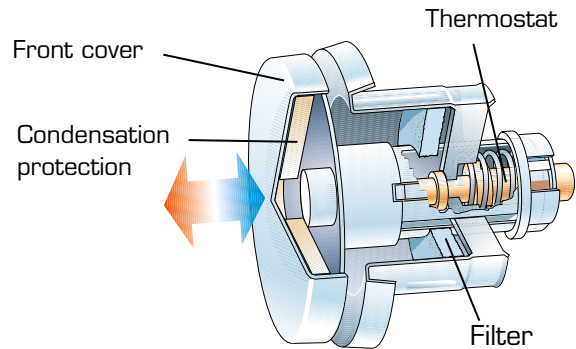

Technical data Fresh 100 Thermo	
Capacity at 10 Pa:	7,5 l/s
Wall opening:	Ø105mm
Max wallthickness:	350 mm. Additional wall pipes are available (accessory)
Material:	ABS-plastic
Colour:	White, RAL 9010
Soundreduction Dn,e,w:	33 dB
Technical data Fresh 100 Thermo-dB	
Wall opening:	Ø150 mm
Max wallthickness:	400 mm. For other lengths please contact Fresh AB.

Capacity

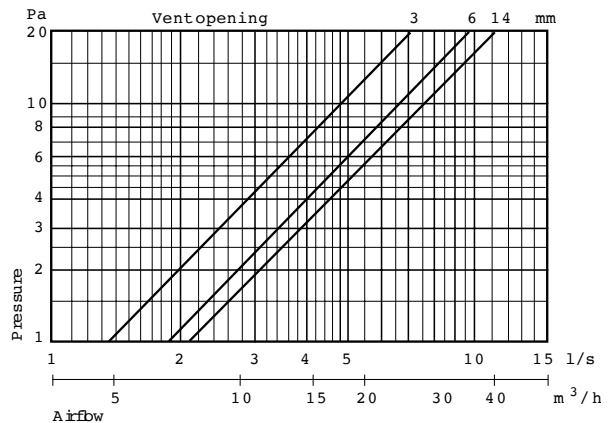

Dimensions

Fresh 100 Thermo, Ø 102mm

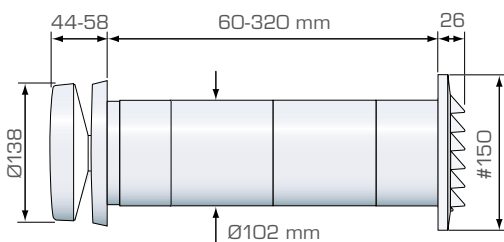

Fresh 100 Thermo-dB

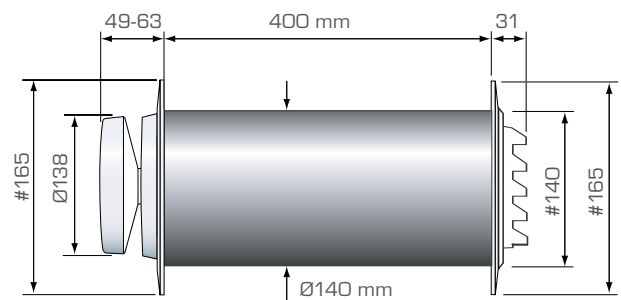

F100 Thermo

Air supply vent

Sound data

The diagrams show sound reduction with fully open vent. The area of calculations are based on a reference area of 10 m².

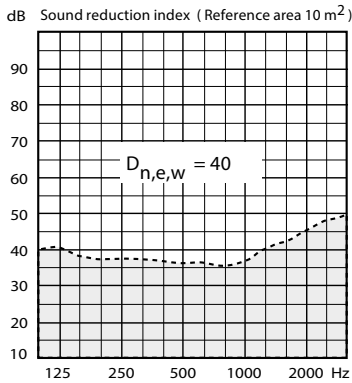

Fresh 100 Thermo-dB with 200 mm wall pipe.

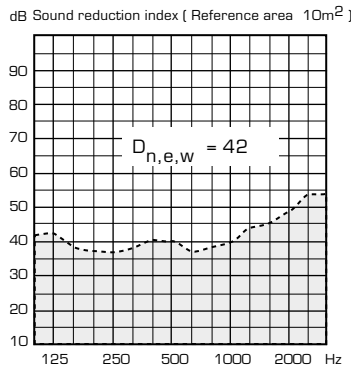

Fresh 100 Thermo-dB with 300 mm wall pipe.

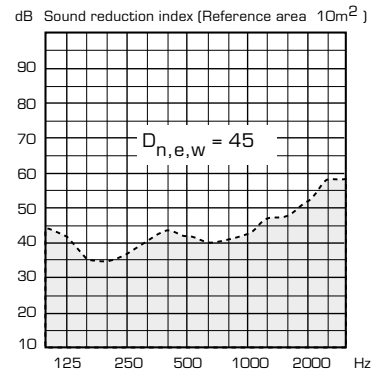

Fresh 100 Thermo-dB with 400 mm wall pipe.

Maintenance

In order to ensure correct airflow and to retain good air quality it is important to keep the filter clean. We recommend to wash/replace the filter 1-2/year.

The Standard filter is washable (use a gentle soap/detergent). The Pollen filter should be replaced with a new filter.

The filter is made accessible by turning the front cover anti-clockwise. Mounting is made in reversed order, turn the cover clockwise until a clicking sound is heard. The vent is now pre-set to initial temperatures.

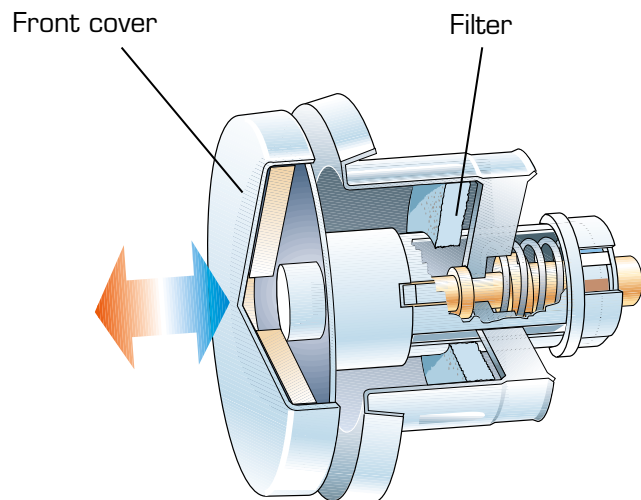

Accessories



Wall tube
Available in different lengths and sizes.



Coverplate
Available in different sizes and colours



Storm shield,
protection against heavy winds and water penetration



Storm shield
regulates air supply during heavy winds



Thermo-brick
Ensures a certain minimum-flow.

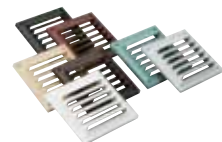

External grille
Available in different sizes and colours